

Title Core Board			HKUST Robocon Hong Kong U.Sci. and Tech. Clear Water Bay, Kowloon Hong Kong
Size: A4	Number:	Revision: 4.0	
Date: 1/11/2006	Time: 12:49:07	Sheet of	
File: C:\Documents and Settings\lgpro\My Document(s)\Robocon\PCB\trunk\coreset\coreset.SCHDOC			

In System Programming

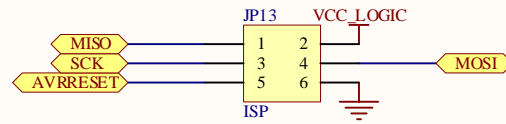

Title Playstation Controller		HKUST Robocon Hong Kong U.Sci. and Tech. Clear Water Bay, Kowloon Hong Kong	
Size: A4	Number:	Revision:	
Date: 1/11/2006	Time: 12:49:26	Sheet of	
File: C:\Documents and Settings\lgpro\My Documents\Robocon\PCB\trunk\coreset\ISP.SCHDOC			

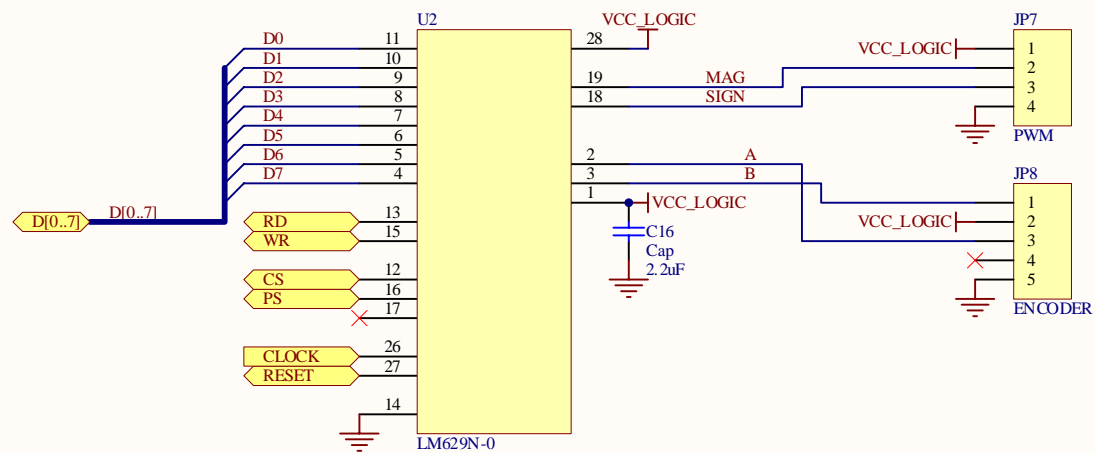

Title LM629			HKUST Robocon Hong Kong U.Sci. and Tech. Clear Water Bay, Kowloon Hong Kong
Size: A4	Number:	Revision:	
Date: 1/11/2006	Time: 12:49:46	Sheet of	
File: C:\Documents and Settings\lgpro\My Documents\Robocon\PCB\trunk\coreset\LM629.SCHDOC			

I2C
 Designed for inter-processor
 communication

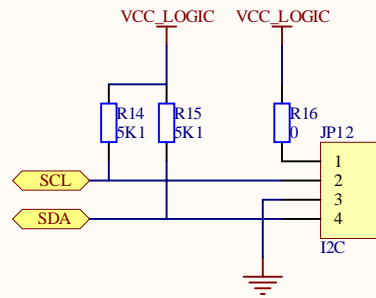

Title IR Demodulator			HKUST Robocon Hong Kong U.Sci. and Tech. Clear Water Bay, Kowloon Hong Kong
Size: A4	Number:	Revision:	
Date: 1/11/2006	Time: 12:50:38	Sheet of	
File: C:\Documents and Settings\lgpro\My Documents\Robocon\PCB\trunk\coreset\I2C.SCHDOC			

Mini-DIN PS2 Host
 For PS/2 keyboard/mouse connection

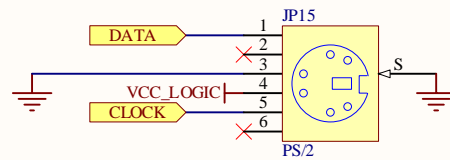

Title PS2			HKUST Robocon Hong Kong U.Sci. and Tech. Clear Water Bay, Kowloon Hong Kong
Size: A4	Number:	Revision:	
Date: 1/11/2006	Time: 12:50:55	Sheet of	
File: C:\Documents and Settings\lgpro\My Documents\Robocon\PCB\trunk\coreset\PS2.SCHDOC			

1

2

3

4

A

A

B

B

C

C

D

D

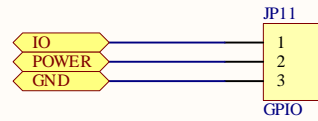

Title <i>GPIO</i>			<i>HKUST Robocon Hong Kong U.Sci. and Tech. Clear Water Bay, Kowloon Hong Kong</i>
Size: A4	Number:	Revision:	
Date: 1/11/2006	Time: 12:51:12	Sheet of	
File: C:\Documents and Settings\lgpro\My Documents\Robocon\PCB\trunk\coreset\GPIO.SCHDOC			

1

2

3

4

Debug mechanism

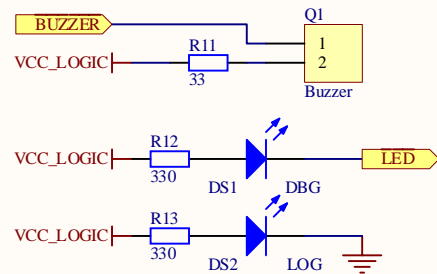

Title RC Servo Motor			HKUST Robocon Hong Kong U.Sci. and Tech. Clear Water Bay, Kowloon Hong Kong	
Size: A4	Number:	Revision:		
Date: 1/11/2006	Time: 12:51:26	Sheet of		
File: C:\Documents and Settings\lgpro\My Documents\Robocon\PCB\trunk\coreset\debug.SCHDOC				

RC Servo motor

The pulldown resistor make sure the signal voltage is defined even when the system is off

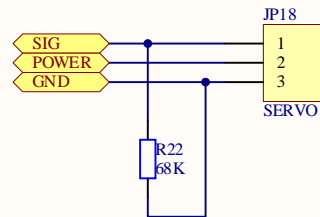

Title RC Servo Motor			HKUST Robocon Hong Kong U.Sci. and Tech. Clear Water Bay, Kowloon Hong Kong
Size: A4	Number:	Revision:	
Date: 1/11/2006	Time: 12:51:40	Sheet of	
File: C:\Documents and Settings\lgpro\My Documents\Robocon\PCB\trunk\coreset\servo.SCHDOC			

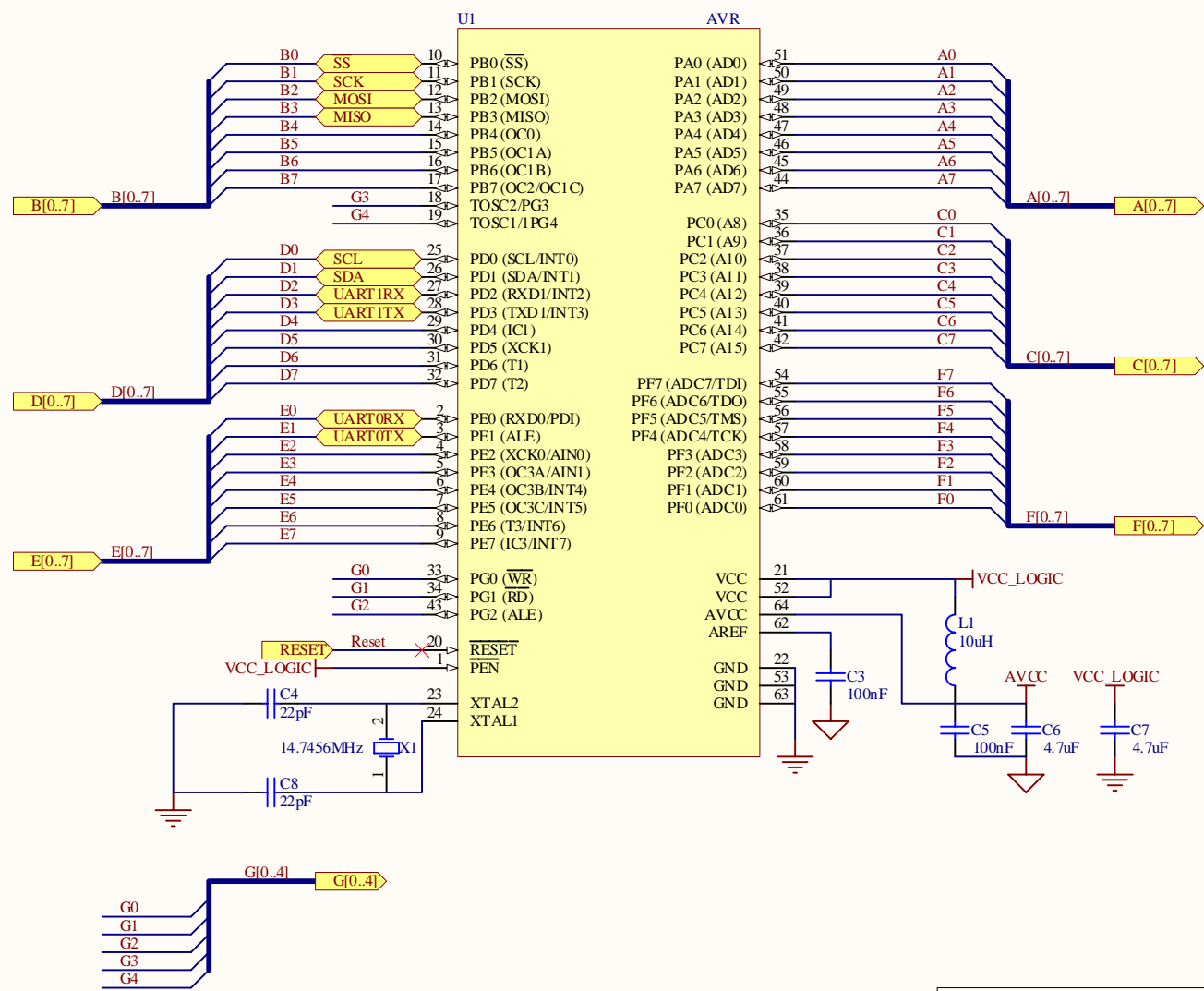

Title MCU		HKUST Robocon Hong Kong U.Sci. and Tech. Clear Water Bay, Kowloon Hong Kong	
Size: A4	Number:	Revision:	
Date: 1/11/2006	Time: 12:51:54	Sheet of	
File: C:\Documents and Settings\lgpro\My Document(s)\Robocon\PCB\trunk\coreset\mcu.SCHDOC			

PWM

The pulldown resistor make sure the signal voltage is defined even when the system is off

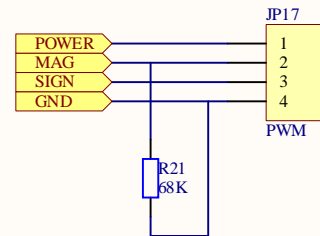

Title PWM			HKUST Robocon Hong Kong U.Sci. and Tech. Clear Water Bay, Kowloon Hong Kong
Size: A4	Number:	Revision:	
Date: 1/11/2006	Time: 12:52:10	Sheet of	
File: C:\Documents and Settings\lgpro\My Documents\Robocon\PCB\trunk\coreset\pwm.SCHDOC			

LCD
 Alphanumeric LCD module with contrast adjustable.
 Normally open R24 and short R25.

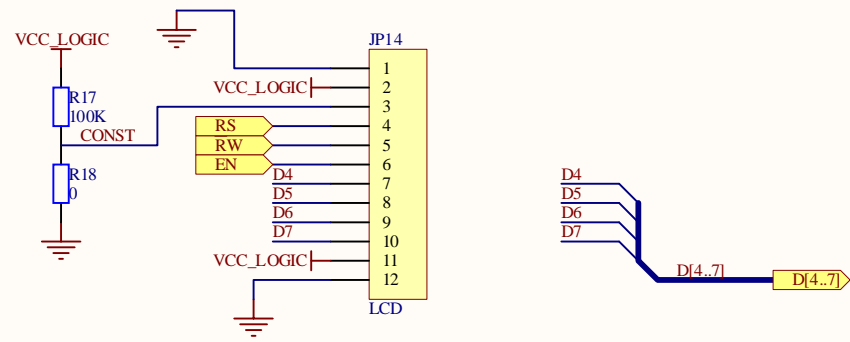

Title LCD			HKUST Robocon Hong Kong U.Sci. and Tech. Clear Water Bay, Kowloon Hong Kong	
Size: A4	Number:	Revision:		
Date: 1/11/2006	Time: 12:52:24	Sheet of		
File: C:\Documents and Settings\lgpro\My Documents\Robocon\PCB\trunk\coreset\LCD.SCHDOC				

RS232 Level Changer
 Disabled when AVR Reset is active, so E0 & E1 which are

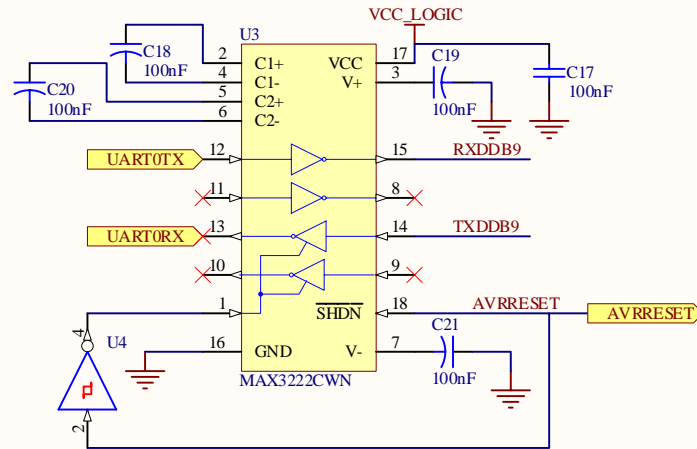

Connection header to ARM (TS-7250)
 With proper placement, could be used to stack over

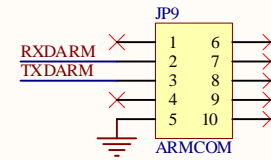

DB9 Header

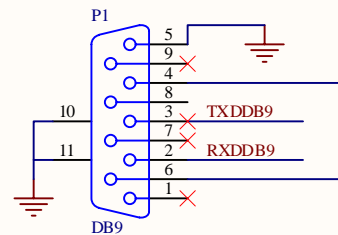

Make or break connection with ARM
 To connect, short [1-3], [2-4]

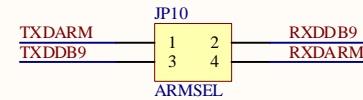

Title UART			HKUST Robocon Hong Kong U.Sci. and Tech. Clear Water Bay, Kowloon Hong Kong
Size: A4	Number:	Revision:	
Date: 1/11/2006	Time: 12:52:35	Sheet of	
File: C:\Documents and Settings\lgpro\My Document(s)\Robocon\PCB\trunk\coreset\UART.SCHDOC			

Playstation Controller
 RJ45 socket for connecting Playstation Controller

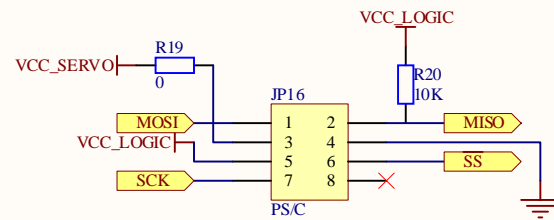

Title Playstation Controller		HKUST Robocon Hong Kong U.Sci. and Tech. Clear Water Bay, Kowloon Hong Kong	
Size: A4	Number:	Revision:	
Date: 1/11/2006	Time: 12:52:46	Sheet of	
File: C:\Documents and Settings\lgpro\My Documents\Robocon\PCB\trunk\coreset\PSC.SCHDOC			

Commercial IR Demodulator

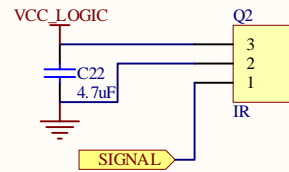

Title IR Demodulator			HKUST Robocon Hong Kong U.Sci. and Tech. Clear Water Bay, Kowloon Hong Kong
Size: A4	Number:	Revision:	
Date: 1/11/2006	Time: 12:52:56	Sheet of	
File: C:\Documents and Settings\lgpro\My Documents\Robocon\PCB\trunk\coreset\IRDemod.SCHDOC			

Input and voltage probe

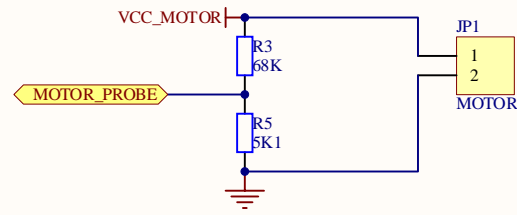

Power Output

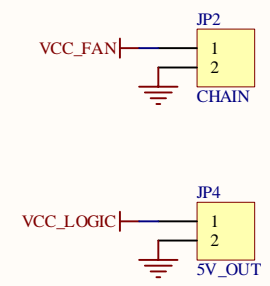

Analog - Digital ground connection

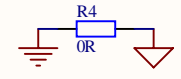

Bucking Switching Regulator
 Input : 6V - 35V
 Output : 5V 4A

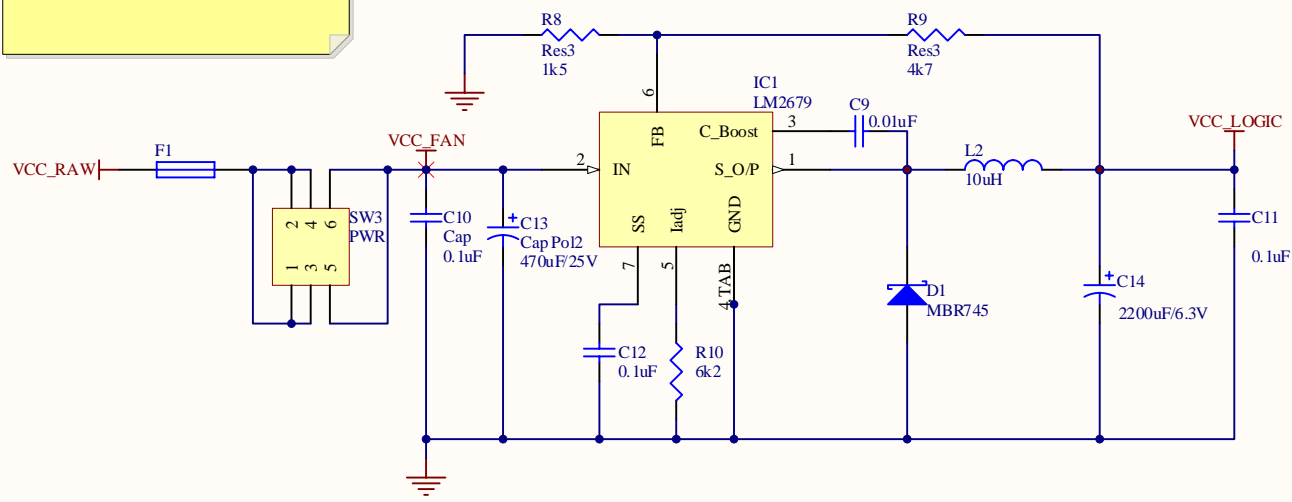

Servo Power Supply
 SPSS - Servo Power Supply Selector
 EPSM - External Power Supply Module, there are some left over switching regulator module which could fit this jumper

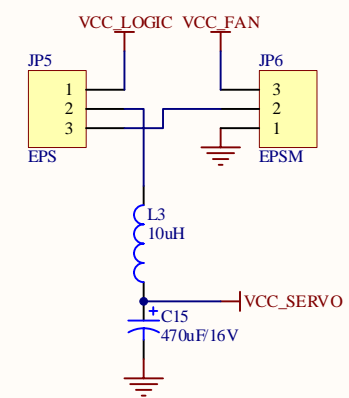

Title Power Supply			HKUST Robocon Hong Kong U.Sci. and Tech. Clear Water Bay, Kowloon Hong Kong
Size: A4	Number:	Revision:	
Date: 1/11/2006	Time: 12:53:08	Sheet of	
File: C:\Documents and Settings\lgpro\My Documents\Robocon\PCB\trunk\coreset\power_supply.SCHDOC			